



# INSTALLATION GUIDE

## Timber Stairs

A Guide to Safe Stair Installation  
from the BWF Stair Scheme

© British Woodworking Federation 2018

# Contents

	Introduction	Page 3
--	--------------	--------

Before Installation		
1.1	General	Page 5
1.2	Checking the delivery	Page 5
1.3	Storage	Page 5

Installation		
2.1	General	Page 7
2.2	Working at height	Page 7
2.3	Temporary fixing of stairs	Page 8
2.4	Clearances	Page 8
2.5	Wall string fixings	Page 9

Assembly		
3.1	Straight flight	Page 14
3.1.1	Wall string	Page 14
3.1.1.1	Notching top of wall string to fit over trimmer (birds mouth)	Page 15
3.1.1.2	Trimming bottom of wall string	Page 16
3.1.2	Outer string	Page 17
3.1.2.1	Notching top newel to fit over trimmer	Page 17
3.1.2.2	Trimming newel at bottom of outer string	Page 18
3.2	Preparing the outer handrail	Page 19
3.3	Half landings	Page 19
3.4	Quarter landing	Page 20
3.5	Winder flights	Page 20
3.5.1	Fitting a quarter turn/winder	Page 22
3.6	Balustrade	Page 24

	Further information	Page 26
	It's all in The Badge	Page 26
	Index	Page 27



## Introduction

The BWF Stair Scheme Installation Guide is intended to provide general information about installing timber staircases, focusing on key areas to ensure that the stairs are safe to use and not compromised by poor practice. The members of the BWF Stair Scheme design and manufacture their stairs so that they will support the necessary loads in both the flights and the balustrades, but poor installation can cause the stability of the stair to be reduced, possibly leading to premature failure of components and ultimately the collapse of the stair.

The installation process itself has inherent risks and care should be taken to adequately support the stair until all the necessary fixings to the surrounding structure are in place. No stair should be used for access until its full load bearing capacity has been achieved and it is securely fixed in place.

If you are looking for simple factsheets and toolbox talks to help project the essence of this guide – “*Top Ten Tips to avoid common staircase problems*” is available via [www.bwfstairscheme.org.uk](http://www.bwfstairscheme.org.uk) as a fact sheet and electronic presentation.



**1**

**Before  
installation**

### 1.1 General

- To ensure the minimum time required for site storage plan the delivery of the stair to be close to the time when it will be installed.
- Take care when handling stair components, particularly long flights, as these can be heavy and may need an assisted lift.

### 1.2 Checking the delivery

- When the stair is delivered to site check the delivery against manufacturer's documentation:



### 1.3 Storage

- For replacement stairs, the new stairs should be delivered a few days prior to installation to allow for conditioning.
- If necessary stair components should be stored in clean, well ventilated conditions, protected from damp and direct sunlight.
- Long items should be kept flat on bearers.

- If components are delivered for more than one stair and are not labelled by the manufacturer, store the parts for each stair separately or mark each item so that they can be easily identified. Do not mix stair parts when installing as stairs will usually be made to suit a particular stairwell arrangement.
- If storing stairs in the building take care not to overload any part of the structure by stacking too many parts together. On upper floors store components near to walls on which the floor joists bear, rather than in the centre of rooms.





# 2

## Installation

### 2.1 General



When installing a stair it is usual to start from the top and work down. There may need to be some preparation of joints and trimming to size of components, where required, before the components are fixed in position and this should be checked prior to starting the installation. Wall strings, newels and landings will need to be fixed to the supporting structure. Consideration should be given to the type of fixings used to ensure that they provide a suitable level of support and that they are appropriate for the timber, block or other material to which the stair is being fixed.

All fixing points should be prepared with clearance holes (through the piece being secured) and pilot holes (into the structure being secured to). Never force a fixing into any material, unless the fixing is intended for that purpose, as this will cause splitting of timber and will weaken the joint. Care when handling should be taken to protect the delicate birdsmouth joint that may have been cut into the wall string (see 3.1.1.1).

### 2.2 Working at height



Care should be taken when installing a stair as the nature of the work will present a risk of falling.

Full protection to the outside of any stair will not be afforded until the complete guarding system, balusters or infill panels and handrails have been fixed in place.

As an alternative, a suitably accredited temporary guarding system may be used until the final guarding is in place. (Accredited to EN 13374:2004, Temporary edge protection systems. Product specification. Test Methods.) The Health and Safety Executive publish advice on working at height on their website at:

<http://www.hse.gov.uk/construction/safetytopics/workingatheight.htm>

### 2.3 Temporary fixing of stairs

A staircase will not be able to provide its full support until it is installed completely with all fixings in place. Until this is achieved there is a chance that elements of the stair could become dislodged from their positions, for example, a newel could fall from its location over a trimmer, or a missing fixing or anchor, could cause unexpected loading to a part of the stair leading to failure.

During the installation process it may be necessary for the installer to use the stair, but this should only be undertaken with caution having ensured that temporary supports, such as a block at the base of the stair to prevent slipping, or temporary propping, is in place before the installer applies any load to the stair. At this time, no guarding will have been fitted so the installer should also consider any risks associated with falling from the stair.

Before a staircase is used for access between storeys the trunk should be fully installed and capable of supporting its intended loads with all fixings, packers and supports in place. Any edges where there is a risk of falling should be protected by the supplied guarding or balustrade or by adequate temporary guarding. (Temporary guarding should be accredited to EN

13374:2004, Temporary edge protection systems. Product specification. Test Methods)

### 2.4 Clearances

The finished size of the stair should not be equal to the sizes measured on site, as this will not afford any flexibility while installing the stair and may not permit parts of the flight to be manoeuvred into position. Consideration should also be given to any finishes that are yet to be applied to the walls of the stair opening, such as, dry lining or plastering. The finished size of a stair can be up to 40 mm less than the “tight” sizes measured on site but any clearances between the stair and any fixing points should be packed out prior to fixing.

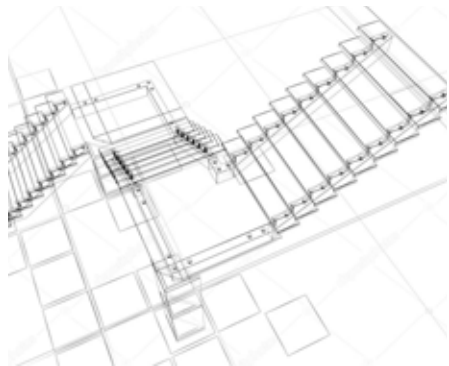



### 2.5 Wall string fixings

Structural screws, which are CE marked to EN 14592, should be used to fix wall strings to timber stud walls or masonry walls. The screws should have a nominal diameter of 5mm (10 gauge), and should either be of the self-drilling type, or should be installed in predrilled holes. The length of the screw should be chosen to achieve a minimum penetration of 50mm into the timber stud/nogging or into the masonry wall, and 50mm long wall plugs should be used in masonry walls (see Figure 1a).

A continuous timber packer of sufficient width to avoid the possibility of splitting should be fixed directly to either the wall or the stair string to fill the gap between stair string and the timber/masonry wall.

The centres appropriate for fixing stair wall strings (including winder strings) are given in Table 1, depending on the size of the gap between the stair string and the wall, and whether the stair is for private or general access.

Figure 1a.

Section through wall string at stud wall and blockwork

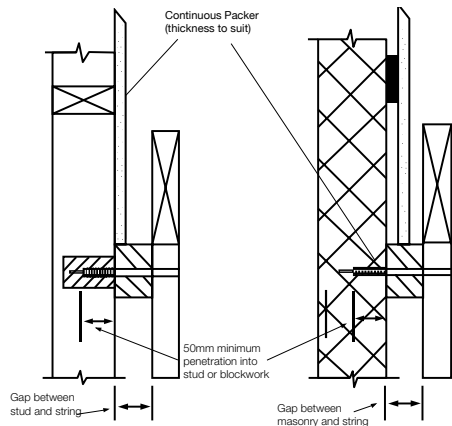

Figure 1.b.

Continuous packer fixed to wall string

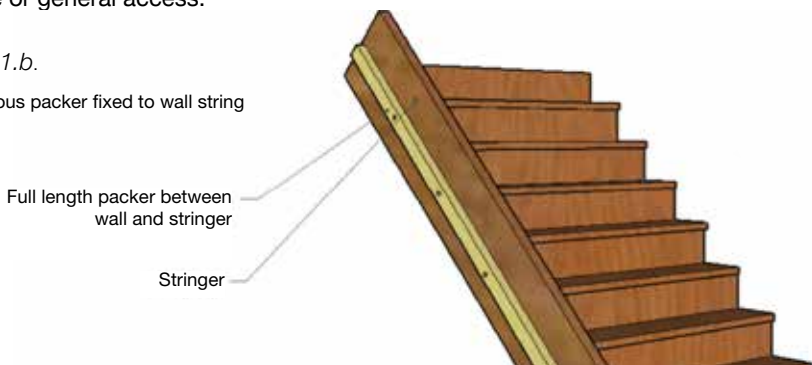

Table 1 – Recommended Stair String Fixing Centres  
(Using 5mm diameter screws penetrating min 50mm into the wall)

Stair usage	String-wall gaps up to 40mm	String-wall gaps exceeding 40mm
Private (domestic)	Max 600mm centres (see Fig 1c)	Max 300mm centres (see Fig 1d)
General access (eg flats)	Max 300mm centres (see Fig 1d)	Seek specialist advice from a structural engineer

Stair string fixing should begin with screws being provided beneath the top and bottom treads.

Working from these top and bottom fixings, additional screws should be inserted at centres no greater than those noted in Table 1, working toward the centre of the string. Note, that this will often result in two fixings being closer than the given centres toward the centre of the string.

Figure 1c

Fixing Centres for private stairs with gaps between string and wall of less than 40mm

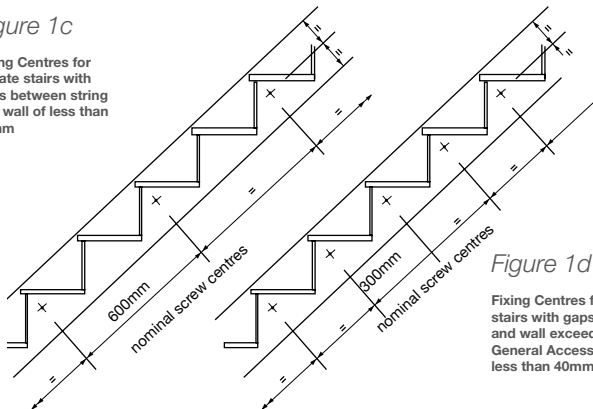

Figure 1d

Fixing Centres for private stairs with gaps between string and wall exceeding 40mm, or General Access stairs with gaps less than 40mm

Figure 1.e.

Fixing Centres for Private stairs with gaps between string and wall of less than 40 mm

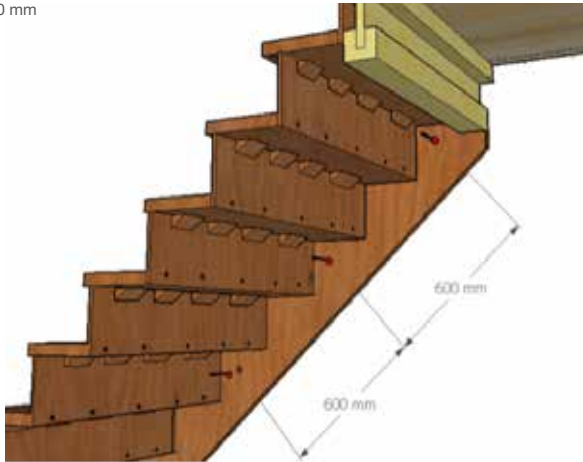
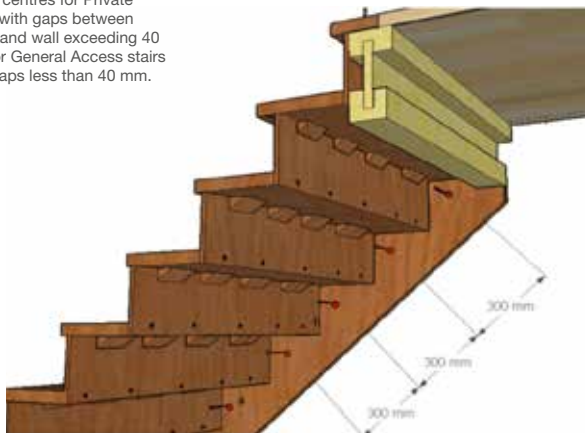

Figure 1.f.

Fixing centres for Private stairs with gaps between string and wall exceeding 40 mm, or General Access stairs with gaps less than 40 mm.



To facilitate fixing into timber stud walls, planed all round (PAR) timber infill pieces should be provided between the vertical timber studs which follow the intended line of the fixings. These timber noggings should be a minimum of 45mm wide x 72mm deep, and be fixed to the timber studs at each end using 2No 75mm long screws inserted perpendicular to the nogging (see Figure 1). Alternatively, additional studs may be provided at 300mm c/c to enable direct fixing into studs and avoid the need for additional timber infill pieces.

**Note:** Steel stud partitions are generally not load bearing and therefore not suitable for supporting the installation of a staircase.

Figure 1g

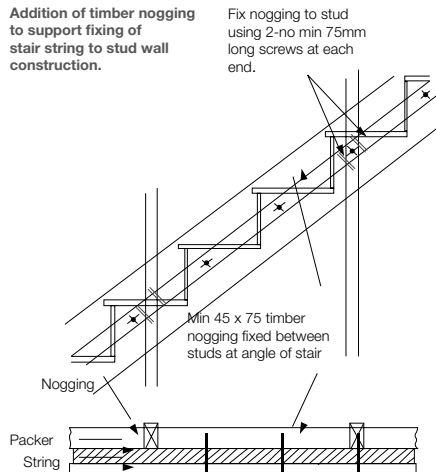
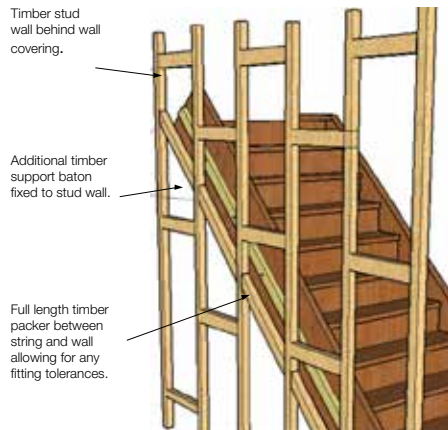

Figure 1.h.

Timber infill pieces should be provided between the vertical timber studs which follow the intended line of the fixings.



Figure 1.i.



**Note:** Wall finish, e.g. plaster, or single or double plaster board, should be accommodated between the structural part of the wall and the stair string.



# 3

## Assembly

### 3.1 Straight flight

#### 3.1.1 Wall string

The wall string is usually cut at its top end to sit over a joist and at its bottom end to sit evenly on a floor or landing.

Figure 2.a.

Top of wall string

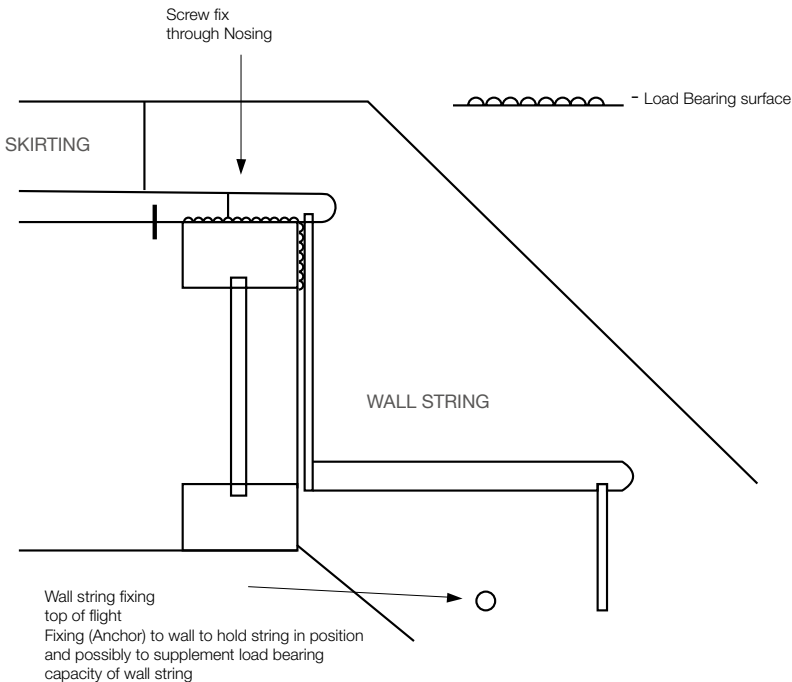

Figure 2.b.

Screw fixing through top nosing into floor joist. Screw fix with countersunk screws. If staircase is not carpeted, screws should be counter bored and capped with a flush timber button.



Figure 2.c.

Fixing the top of the stringer to the wall.



Figure 2.f.

Bottom of wall string to trimmer

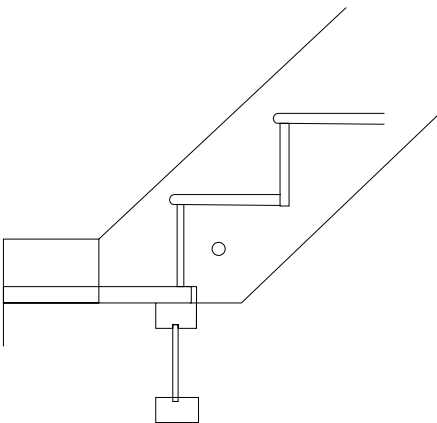

#### 3.1.1.1 Notching top of wall string to fit over trimmer (birds mouth)

If not supplied by the manufacturer pre-cut, cut the underside of the string so that the top face of the top nosing piece will sit flush with the surface of the flooring and the back of the top riser sits against the trimmer but a clearance of up to 5mm can be accepted. Cut the upper side of the string so that it aligns with the skirting.

#### 3.1.1.2 Trimming bottom of wall string

If not supplied by the manufacturer pre-cut, cut the underside of the string so that the vertical measurement from the top surface of the top tread to the underside at the bottom of the string is equal to the overall rise.

**Note:** The upper surface of the housing for the bottom tread can be used as a datum.

For example, if the designed total rise is 2600mm for 13 individual rises of 200mm but the floor to floor measurement taken on site is 2597mm then the bottom rise can be trimmed to 197mm ( $12 \times 200\text{mm} + 197\text{mm} = 2597\text{mm}$ )

**Note:** Sometimes bottom risers and newels are left intentionally long so that any slight deviation between designed total rise and the floor to floor measurement on site can be accommodated. Any difference, however, should be no more than  $\pm 5\text{mm}$ .

If the bottom rise varies by more than this when compared to the designed rise of the other steps a trip hazard would be created.

Figure 2.d.

Bottom of wall string to floor

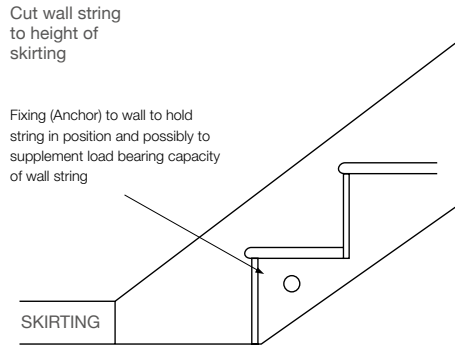

Figure 2.e.

Fixings location and number at the bottom of the inner string.





#### 3.1.2 Outer String

The outer string is usually jointed at the top and bottom ends into newel posts (or newel bases). The most common form of joint is a mortise and tenon joint, although stair manufacturers may provide an alternative method of securing the newels to the outer string. Follow the instructions from the stair manufacturer to ensure the string-to-newel joints are formed correctly. Before fixing, the newels to the outer string will need to be prepared as follows;

Figure 2.g.

Top of outer string

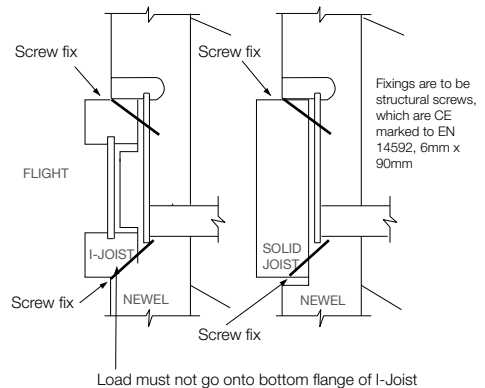

#### 3.1.2.1 Notching top newel to fit over trimmer (birds mouth)

The back face of the newel will need to be notched to receive the trimmer. The notching should position the top nosing flush with the surface of the floor and the back face of the top riser with the same clearance as created by the cutting of the wall string.

**Note:** Notch the newel to the depth of the trimmer, but do not fit the newel over the flooring. Remove the flooring (i.e. chipboard) to accommodate the wall string, newel and top nosing.

Figure 2.h.

Bottom of outer string on trimmer

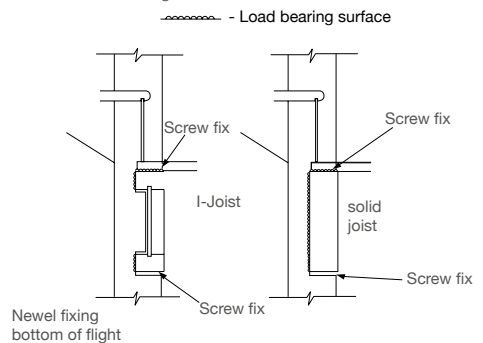

#### 3.1.2.2 Trimming newel at bottom of outer string

Before fixing the bottom newel to the outer string the bottom end of the newel may need to be trimmed to the correct total rise or floor to floor site measurement. (Refer back to the section on cutting the wall string).

**Note:** the bottom newel may not be at the bottom of the flight. There could be up to three additional steps to be fitted.

For example, if the maximum height is 600mm without balustrade and an individual rise less than 200mm there may be a bullnose step, or a bullnose step together with a curtail step.

It may be necessary to remove bottom of newel to assist with access for fitting.

Fixings are to be structural screws, which are CE marked to EN 14592, 6mm x 90mm.

Figure 2.i.

Bullnose treads - plan view

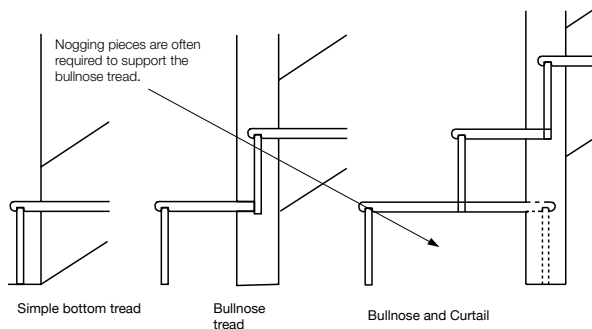
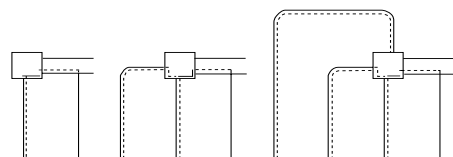

Figure 2.j.

Bottom treads - plan view



### 3.2 Preparing the outer handrail

Handrails are used to support a person using the stairs in the event of a trip or a slip and to provide assistance to people with impaired movement. Handrails can also form the top of a balustrade or “safety barrier” protecting users of the stair from falling. It is essential that handrails are fixed securely.

Once the top and bottom newel have been fixed in position it will not be possible to “spring-in” a tenoned handrail. Do not remove the tenons as this will weaken the joint between the handrail and the newel.

If the handrail is provided with a mechanical fixing system please refer to the manufacturer’s instructions.

When fixing the base rail, screw fixings should be positioned 100mm from each end and at 600mm (minimum) centres thereafter.

The screw length should be specified to ensure adequate length to fix through any floor thicknesses and into the floor joist below. The head of the screw should be flush to the top surface of the base rail, to prevent any interruption when the timber infill pieces are fitted between balusters into the base rail.

**Note:** A handrail on its own cannot act as a safety barrier. Full protection from falling will only be afforded by the

completed guarding system or a suitably accredited temporary guarding system.

### 3.3 Half Landings

Half landings will need to support the same loads as the floors of the property into which the stair is being installed.

The trimmer onto which the top of one flight and the bottom of the second flight will bear will need to support the loads imposed when the flights are being used.

Unless specified otherwise half landings should use the following minimum joist sizes up to a maximum landing size 1.2 m x 2.6 m.

Trimmers should be let into the walls, but not into cavities, for support or supported by joist hangers. Joists can be screwed or bolted to walls. Where trimmers are doubled, the two sections should be screwed or bolted together to avoid slippage and to share the imposed loads from the flights.

The top of the lower flight should be prepared as if the landing was an upper floor (see Figure 4). The bottom of the upper flight should be prepared as if the landing was the lower floor with the newel finishing in-line with the bottom riser (see Figure 5).

The flights should bear on the trimmer and not on the boarding used to form

**Table 2 - Joist and trimmer sizes for half landings**  
Timber to be equivalent to C24 grade or better

Type of stair	Joists at walls and at 600 mm centres max (mm)	Trimmer between walls (mm)
Domestic	47 x 147	2 x 47 x 195
Common	47 x 195	2 x 47 x 225

the surface of the landing. This will allow the boarding to be replaced if it becomes damaged. To maintain the rise of the bottom step is consistent with the rest of the flight, an allowance equal to the thickness of the boarding of the landing will need to be made when cutting the string or newel and bottom riser for height.

#### 3.4 Quarter landing

Quarter landings will need to be able to support the same loads as the floors of the property into which the stair is being installed.

The newel forming the corner of the stair where the outer string turns through 90 degrees will need to be notched to receive and support the outer corner of the landing, unless the newel is designed to be face fixed.

If the newel is to be notched, it will need to act as both a “top” and “bottom” newel for the outer strings and be

prepared in two directions accordingly.

The joist sizes should be as given above for half landings in Table 2. (Trimmers are not required for quarter landings.)

#### 3.5 Winder flights

Winder flights are usually formed of three or four tapered treads radiating from a central newel. This newel will be housed to receive the narrow part of some of the treads and one side of the risers in between. The winder flight may form the top or bottom of the stair or may have straight flights continuing the stair above and below.

Where the winder flight is at the top of the stair, the newel and wall string will need to be prepared to fit over the trimmer in a similar manner to the top of a straight flight. If the winder flight forms the bottom of the stair, the newel and wall string will need to be prepared

in a similar manner to the bottom of a straight flight.

Where the winder flight has straight flights above and below, the outer strings of these flights will need to be fixed to the winder newel in the appropriate manner.

In all cases the two sections of the wall string will need to be joined together and securely fixed to the supporting structure. If the stair is being installed from the top down then the upper wall string will be extended to the full width of the stair and the end of the wall string of the lower flight will be fixed to it.

Due to site limitations, it is not always possible to assemble a winder flight as described above. In this instance the flight should be fully assembled and either lowered or raised into position.

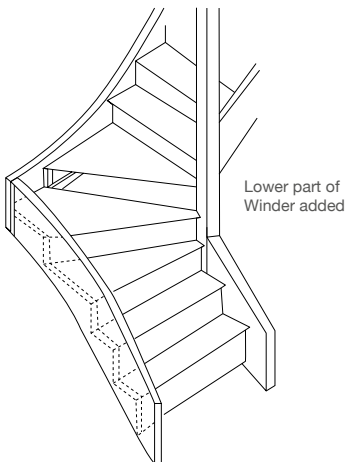
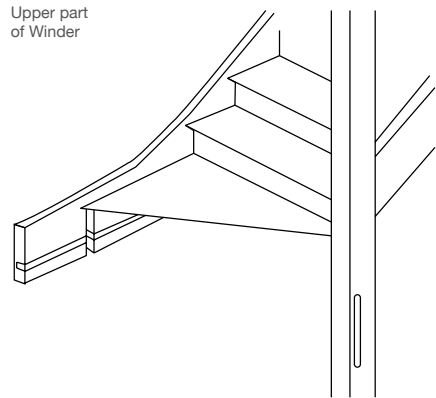

#### 3.5.1 Fitting a quarter turn/winder

**Step 1:** Ensure all parts are present and correct and in good condition.

**Step 2:** Assemble the upper straight flight and locate and fix the string to the wall.

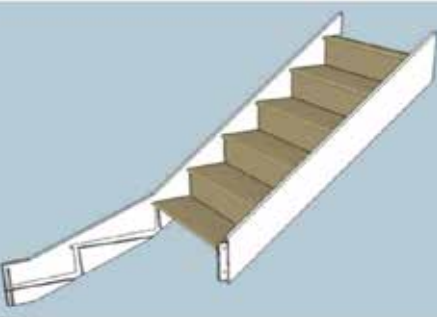

**Step 3:** Locate the tenon on the bottom of the upper string to its equivalent mortise on the newel post. The joint should have a suitable wood adhesive applied to all surfaces and dowels should be inserted into pre-drilled holes to secure the assembly.



**Step 4:** Slide the first winder tread into the string housings from the back. The housings should have adhesive applied to all faces and the wedges inserted to secure the tread.

**Note:** The wedges should also be glued. Any excess adhesive should be removed with a damp cloth.

Also Some parts of the stair may be supplied pre-assembled.

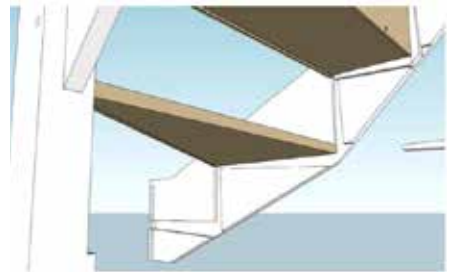
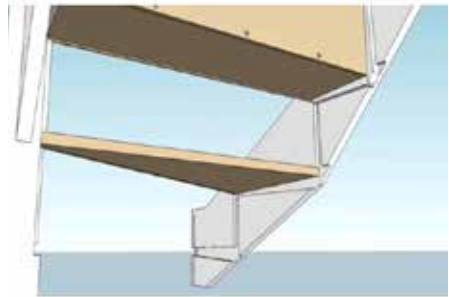

**Step 5:** Slide the first winder riser up into its locating housing on the newel and the string. Screw through the back of the riser into the tread.

**Note:** Glue should be applied to the housings and all holes should be predrilled to prevent timber from splitting. Screws used should be as per the recommendations of the manufacturer.

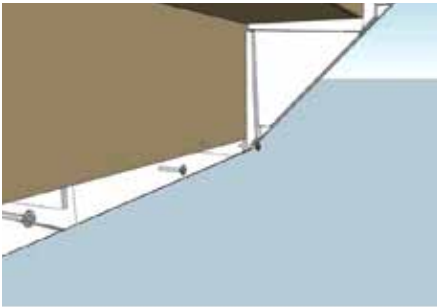

**Step 6:** Slide the next string into the housing in the upper string. The winder tread should also be located into the mortise on the lower string. Adhesive should be applied to both mortises. The tenon on the outer string should locate into the mortise on the newel post. Adhesive should be applied to both surfaces and dowels inserted through predrilled holes.

**Note:** Dowels should be glued and excess adhesive removed with a damp cloth.

**Step 7:** Fix any remaining winder treads and risers as above.



**Step 8:** Fix supporting timber blocks underneath treads. Blocks should be applied using adhesive and secured by a mechanical fixing as per manufacturers recommendation.

**Note:** On a standard private stair 4 x blocks should be applied under each of the winder treads.





### 3.6 Balustrade

Other than at the two bottom steps, a barrier is required to protect users of the stair from falling. This is often provided by a balustrade formed by individual balusters or spindles. So as to provide the necessary protection it is important that the balustrade is fixed securely.

Once the stair has been fully assembled and secured in place the balustrade can be fitted. If the balustrade has been delivered as an assembled unit then fit in accordance with the manufacturer's instructions.

If the balustrade has been delivered as components, start to form the balustrade by cutting to length and angling the ends of the string capping, balusters or spindles and infill piece.

The string capping should be cut to fit tightly between the newels with its ends angled to suit the pitch of the flight. Once cut the string capping should be screw fixed to the string starting 100mm from each end and then at no more than 600mm centres.

The balusters or spindles should be cut to length so that they fully engage into the groove in the underside of the handrail and the upper face of the string capping. Again, the ends of the balusters should be angled to the pitch of the stair. It is important that balusters are fully housed by the handrail and string capping or they may not provide the necessary protection to users of the stair.



Figure 2.k.  
Handrail and guarding.

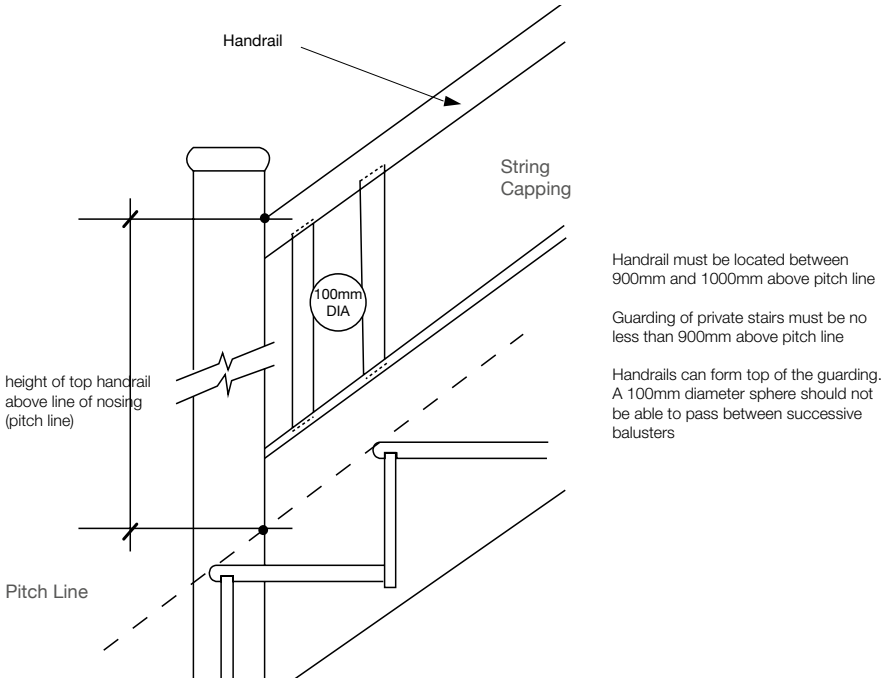

The infill pieces will fill the grooves in the handrail and string capping in between the balusters. They should be cut so that the balusters are evenly spaced and so that no part of the gap between two adjacent balusters would allow a 100mm diameter sphere to pass through; pay particular attention to turned balusters. It is not necessary for the spacing at the

top and bottom newel to be the same as the rest of the balustrade, so, while the spacing between other balusters should be consistent, any adjustments can be made by altering the spacing at the newel. Each baluster should be fixed by gluing and pinning on both the upper and lower faces. The infill pieces should also be glued and pinned.

### Further information

Visit [www.bwfstairscheme.org.uk](http://www.bwfstairscheme.org.uk) to see more guidance including:



***Design Guide 1 for Private Stairs***



***Design Guide 2 for Common Stairs***

### It's all in The Badge

The BWF Stair Scheme is the only accreditation and certification scheme of its kind in the UK. Ranging from domestic, common and fire protected common stairs, the standard expected of the manufacturers for their stairs is extremely high to ensure quality and safety.

All companies within the scheme are regularly audited to ensure their products and their production meet these high standards. The new third-party certification for fire protected common stairs, supported by the Loss Prevention Certification Board (LPCB) is opening up new markets for timber stairs. The scheme is managed by the BWF, and includes manufacturers, as well as approved suppliers, who play an important part in maintaining these high standards.



## A

adhesive 22, 23

## B

baluster 7, 19, 24, 25  
balustrade 3, 8, 18, 19, 24, 25  
bearer 5  
birdsmouth joint 7  
block 7, 8, 23  
bullnose step 18

## C

CE marked 9, 17, 18  
clearances 8  
component 3, 5, 7, 24  
curtail step 18

## D

delivery 5  
documentation 5  
dry lining 8

## F

fixing 3, 7, 8, 9, 10, 12, 16, 17, 18, 19  
flight 3, 5, 8, 14, 18, 19, 20, 21, 22, 24

## G

guarding 7, 8, 19, 25

## H

half landing 19, 20  
handrail 7, 19, 24, 25

## I

infill panel 7  
installing 7, 8

## J

joint 7, 17, 19, 22  
joist hanger 20  
joist 5, 15, 17, 18, 19

## L

landing 7, 19, 20

## N

newel 7, 8, 16, 17, 18, 19, 20, 21, 22, 23, 24  
nogging 9, 12, 18

## O

outer string 17, 18, 20, 21, 23

## P

packer 8, 9, 12  
plastering 8

## Q

quarter landing 20  
quarter turn 22

## R

riser 14, 16, 17, 20, 21, 23

## S

stair string 9, 10, 12  
storage 5  
string capping 24, 25  
stud 9, 12  
support 3, 7, 8, 12, 18, 19, 20

## T

tapered tread 21  
timber stud walls 9, 12  
top nosing 14, 15, 17  
tread 10, 16, 18, 19, 21, 22, 23  
trimmer 8, 14, 17, 18, 19, 20, 21  
trimming 7, 16, 18  
trunk 8

## W

wall string 7, 9, 14, 16, 17, 18, 21  
winder flight 21  
winder tread 22, 23  
working at height 7



# INSTALLATION GUIDE

## Timber Stairs

A Guide to Safe Stair Installation  
from the BWF Stair Scheme

© British Woodworking Federation 2018

The British Woodworking Federation  
26 Store Street  
London WC1E 7BT  
0844 209 2610  
[bwf@bwf.org.uk](mailto:bwf@bwf.org.uk)